

Produkt  
product



Product

## Flip-Flow-Screen ELASTICA

The clogging free screening solution for recycling materials



© Spaleck

### Application

Screening of difficult, sticky or wet materials to an infinite variety of sizes

### Material

Wet, moist, dry and mixed materials e.g. recycling and skip waste fines material, compost, aggregates, waste wood, timber etc.

### Advantages

- Non blinding screening mats - less contamination
- Compact and modular construction
- Single- or multi-deck execution
- Dynamic wear resistant screening mats allow an efficient material flow - screwless mounted (fast changeover).
- The high acceleration on the screening mats ensures a self-cleaning effect.
- Infinite adjustment of the vibrating parameters to match changing product characteristics / qualities
- Low operating and maintenance costs

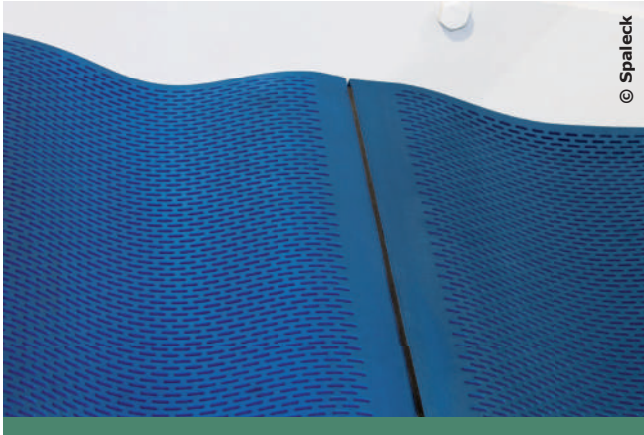

© Spaleck



MSW



C+D/C+I



Incineration slag



Shredder light fraction



Shredder heavy fraction

## Flip-Flow-Screen ELASTICA

The base frame is agitated by means of shaft and unbalance motor drive. The vibration is passed to the dynamic frame via thrust rubbers.

Fixed screening mats between the dynamic and the base frame are clamped and flexed by the two vibrating frames.

The modular and compact construction of the SPALECK Flip-Flow-Screen ensures a wide acceptance for many different applications.

The easy assembly respectively changing of the screening mats, the extension to a multi-deck version and the dynamic stroke adaptation are further features.

The vibrating cover can be opened without tools. This ensures a rapid and easy accessibility of the screening mats.

### Functional principle:

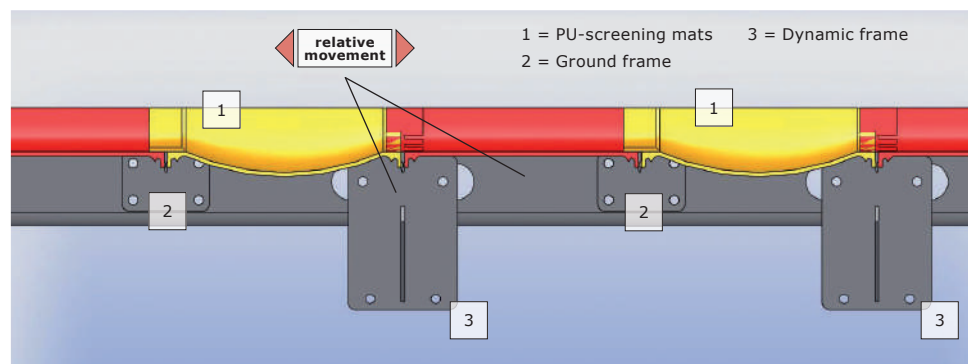

The relative movement of both screening frames creates a "trampoline effect" for the screening mats. The advantages of this effect are:

- High acceleration up to 50g in the screening mats
- Loosening-up of the product

Spaleck GmbH & Co. KG  
Robert-Bosch-Straße 15  
46397 Bocholt/Germany

Fon +49 2871 2134-0  
Fax +49 2871 2134-24  
f-s@spaleck.de · [www.spaleck.de/f-s](http://www.spaleck.de/f-s)

**SPALECK**® since 1869  
conveying and separation technology

progress through diversity