

SORTEX A  
*MultiVision*

SORTEX® A  
optical sorter.  
**The pinnacle of  
optical sorting.**



# Bühler in partnership with processors.

## **An integrated partner in commodity sorting.**

Available in four variants - the SORTEX A, SORTEX A DualVision™, SORTEX A ColorVision™ InGaAs and SORTEX A MultiVision™, demonstrating a commitment to providing processors with dedicated customised options to sort unique and customer specific sorting requirements.

Showcasing Bühler innovation with new advanced inspection and lighting systems, this state-of-the-art technology provides the ultimate sorting solution, whatever the difficulty of the application.

- Empowering sorting performance
- Ensuring consistent operation
- Optimising productivity, lowering cost of ownership

# SORTEX A. The pinnacle of optical sorting.

Process engineered with flexibility to handle small to large capacities, the SORTEX A range is available in one to five module versions, in three different frame sizes. Depending on requirements, the sorters can be customised with tailored options to meet individual processing requirements.



One module



Two/Three module



Four/Five module

Trusted performance across a range of commodities.

■ Accept ■ Reject

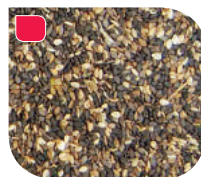

Barley

Red Lentils

Black Sesame

Plastics

Coffee

Almonds



# SORTEX A optical sorter at a glance.

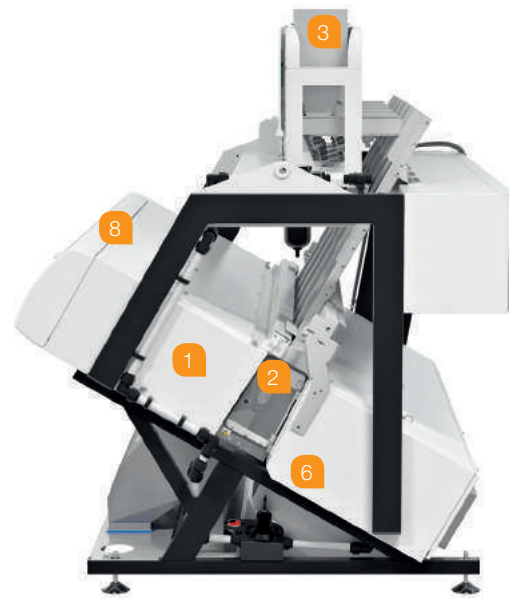

- 1 Advanced inspection system**  
Ultimate detection of all known defects and foreign material for the most complex sorting applications
- 2 Broadband LED Lighting**  
Flexible solid state LED lighting that improves illumination and enhances defect recognition
- 3 High capacity feed system**  
Available with up to five chutes for flexible sorting configuration
- 4 SmartEject™ technology**  
Fires precisely at the whole object to ensure efficient removal
- 5 SORTEX ProSortX™ operating software**  
Simplifies a wealth of configurable options with unmatched processing speed
- 6 Automated Background**  
Background adjusts as light levels vary delivering consistent operation
- 7 Simultaneous re-sorting**  
Maximises recovery of good product by achieving the highest reject concentration
- 8 Sealed optical and control cabinets**  
Rated up to IP5X to protect against dust ingress maintaining a stable and reliable operation in dusty environments
- 9 Remote access for real-time monitoring**  
Real time monitoring by Bühler engineers of the performance of the sorter from anywhere in the world
- 10 Low power and air consumption**  
For reduced operational costs
- 11 ATEX Compliant**  
Certified for use in hazardous environments



Nuts



Seeds



Grains



Coffee



Pulses



Plastics

# SORTEX A variants.

## Visible inspection system.

Bühler's comprehensive product portfolio has been carefully developed to offer processors the best solutions for conventional and challenging sorting applications. The SORTEX A range has four technology variants, each designed in different levels for defect detection.

### What does each variant detect?

#### SORTEX A



#### Independent light or dark sorting

The SORTEX A uses one visible wavelength

This is best suited for mainstream colour sorting applications which include removing light or dark defects.

#### SORTEX A DualVision™

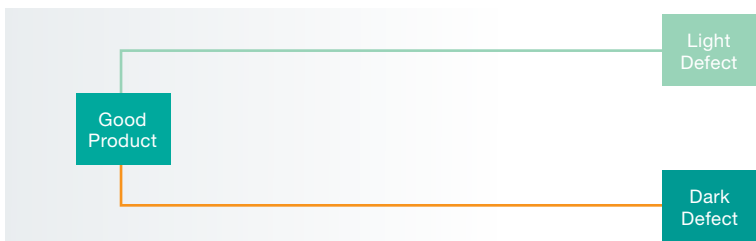

#### Simultaneous light and dark sorting

The DualVision™ uses two visible wavelengths independently

This is for detecting both light and dark defects simultaneously.

#### SORTEX A ColorVision™ InGaAs

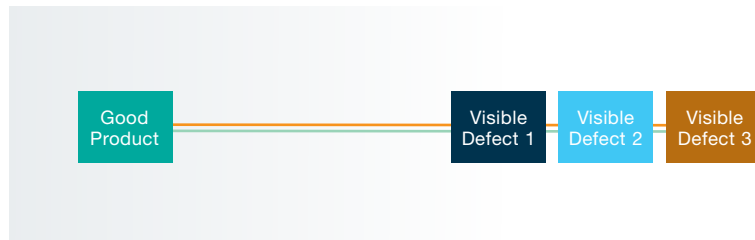

#### Superior colour sorting

The ColorVision™ uses two of the three visible wavelengths together with the SW IR shortwave detection (InGaAs)

This can detect not only light and dark defects but also other colour variations.

#### SORTEX A MultiVision™

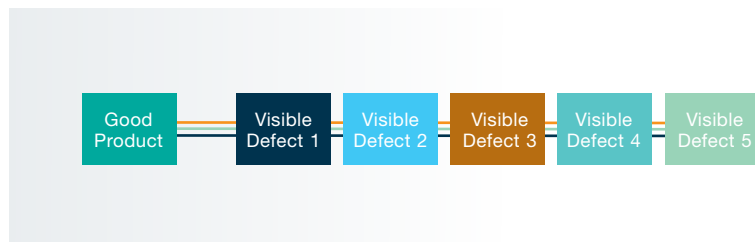

#### Subtle colour sorting

The MultiVision™ uses multiple visible wavelengths

Detecting the subtlest colour variations.

# SORTEX A technology. Innovation and leadership.

Reliable and consistent machine performance for a uniform, premium quality end product. Bühler proprietary technologies minimise loss of good product while maximising profitability. Innovative technology to remove subtle colour variations and challenging foreign materials, meeting the needs of all processors.

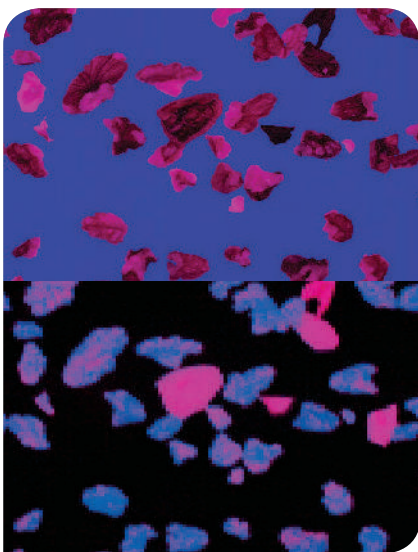

Visible camera frame capture  
InGaAs camera frame capture

## InGaAs Technology

Derived from a product originally designed for military satellite application, InGaAs technology can detect defects which cannot be seen in the visible spectrum. By utilising infrared technology, the system reads light reflection as well as colour registration to offer precise, authoritative detection.

InGaAs provides much better separation of good product from foreign material of the same colour for safe, reliable product.



Flexible broadband LED lighting

## Inspection system with LED and IR lighting

Bühler's high-resolution cameras are designed and built in-house to deliver the colour contrast needed to detect defects and foreign material. Engineered to the highest standards, when combined with LED or IR lighting, Bühler optical sorters can target defects within and outside the entire visible spectrum.

Developed and optimised over many years, SORTEX cameras and lighting systems utilise the very latest in optical registration technology.



Streamlining everyday sorting tasks

## SORTEX ProSortX™ operating software

The latest update of Bühler's proprietary operating software comes with a fresh new interface that's modern, clean and intuitive to use.

Featuring innovative FingerTipControl™ and all-new Bühler ATOM™ board for faster processing and navigation between screens.

# PROfile™ Technology

## Three powerful proprietary analysis systems.

A combination of three dynamic technologies which enable Bühler optical sorters to perform even the most complex sorting tasks. Designed with multiple levels of **shape**, **size** and **colour** detection to deliver consistent, uniform product quality at the highest capacity possible. This unique double detection system analyses produce from both sides to offer processors total quality assurance.



Defects objects identical in colour.



Delicate produce is size graded with ease.



Combining multiple blemishes to define true product value.

### PROshape™

Designed by SORTEX experts, **PROshape™** is an intelligent detection technology which inspects product based on shape criteria when the defective product is the same colour as good product.

**PROshape™** uses multiple detection criteria options, combining them to:

- Remove foreign material matching the colour of good produce such as sticks, stems or leaves to maximise product safety

### PROsize™

Bühler's **PROsize™** technology is a detection solution which sorts objects based on size characteristics to maximise product uniformity and value.

Far advanced from traditional grading solutions, **PROsize™** can be employed in situations where product is too delicate or difficult to be sorted using conventional mechanical graders, maximising profitability by distinguishing the premium product.

**PROsize™** is an ideal solution to:

- Separate under sized produce
- Separate over sized produce\*
- Remove broken produce

### PROcolor™

**PROcolor™** is a breakthrough technology completely unique to Bühler. The state-of-the-art process works by analysing product based on multiple colour variations, as well as by the area of the individual blemishes.

Processors can define the maximum percentage of surface blemish based on retail or customer specifications, enabling them to grade products on their physical appearance.

- Maximise commodity value by defining multiple grades of quality product
- Adds greater value to product by setting higher limits of quality



# SORTEX A specifications.

## Technical details.

### Product options

SORTEX A	SORTEX A	SORTEX A InGaAs	DualVision™	DualVision™ InGaAs	ColorVision™ InGaAs	MultiVision™	MultiVision™ InGaAs
Flexible Colour Cameras					■	■	■
InGaAs Technology		■		■	■		■
PROfile™ Technology					■	■	■
LED Lighting	■	■	■	■	■	■	■
IR Lighting		■		■	■		■
Climate Control	●	●	●	●	■	●	■
Remote Access	●	●	●	●	●	●	●
SORTEX ProSortX™	■	■	■	■	■	■	■
CE Certification	■	■	■	■	■	■	■
ATEX	●	●	●	●	●	●	●
SORTEX TotalCare™	●	●	●	●	●	●	●
Available Modules	1 - 5	1 - 5	1 - 5	1 - 5	1 - 5	1 - 5	1 - 5

■ Standard      ● Optional

For the full feature list and product specifications contact your local representative.

### Dimensions, air and power requirements

#### Dimensions

Machine	Width mm	Depth (Doors Open) mm	Depth (Doors Shut) mm	Height mm	Weight* kg
A1	1000	2333	1708	2088	500
A2	1788	2333	1708	2088	927
A3	1788	2333	1708	2088	970
A4	2387	2333	1708	2088	1107
A5	2387	2333	1708	2088	1150

\* Unpacked weight. Figures will vary based on machine specifications

#### Air and power requirements

Machine	Typical air requirements (L/s)* 72-102 psi (5-7bar)	Typical Power consumption (kW)** (200-240V; 50/60 Hz single phase)
A1	8	1.5
A2	16	2.3
A3	24	3.1
A4	32	3.4
A5	40	4.5

\* Figures will vary based on contamination levels

\*\* Figures will vary based on machine specifications



SORTEX A

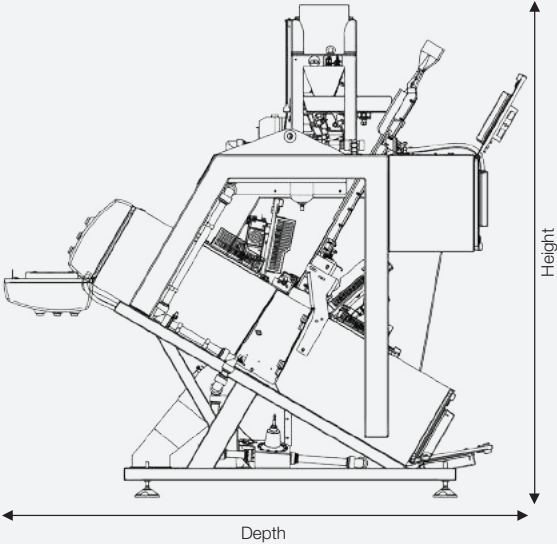
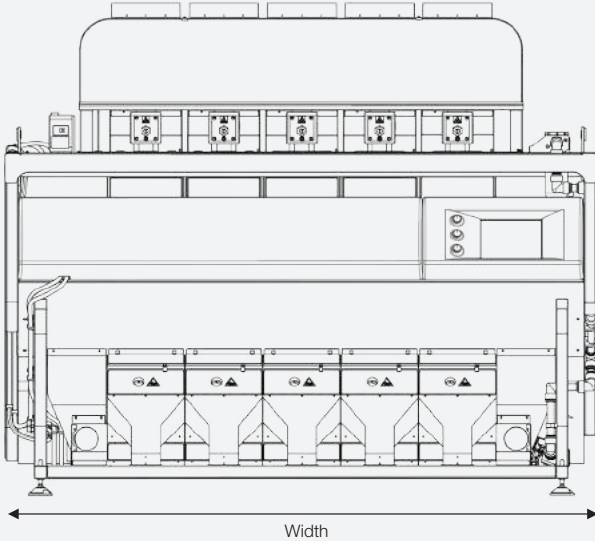

# SORTEX Customer Care. Secure tomorrow's profits today.

Bühler's worldwide Customer Care organisation delivers the highest quality local support ensuring optical sorters perform at maximum possible efficiency, deliver optimum productivity and make the best return on investment.



## The SORTEX Spare Parts promise.

Customer satisfaction is our priority. This is why we strive to deliver spare and wear parts within 48 hours, doing our best to limit your downtime and maximise your profitability.

For customers who require spare parts available on site, Bühler's technologists have created appropriate spare kits for the different machinery available.

# TotalCare™

## Performance protection.

TotalCare™ allows customers to create their own service package, composed of individual service features that best suit their needs. Customers can create a tailored programme from a variety of packages. Contract options vary from basic to fully comprehensive cover. This way, investments can remain fully protected.

### TotalCare Protect

#### Minimise Downtime

Based on an agreed number of annual visits, Bühler engineers will replace key wear parts, provide consultation and advise on future maintenance requirements.

Protecting Investment.

### TotalCare Perform

#### Performance Optimisation

Aspiring to keep downtime to under 24 hours, sorters will be safeguarded against any failed components. Bühler engineers will ensure first-rate performance once the repair is carried out.

Repair and Optimise.

### TotalCare PerformPLUS

#### Ejector Refurbishment

Making certain that sorters are running at peak performance, ejectors are replaced when the stipulated life-cycle is reached. Performance is maintained for the future.

Maximum Capacity and Quality.

Customers can tailor their individual package from the following options

### TotalCare Anyware

#### Supervised Functionality

Provides a working record of operational information as well as reports that enable machine health to be monitored and preventative maintenance scheduled.

Maintain Optimised Performance.

### TotalCare AnywarePRO

#### Remote Access and Assistance

Sorter performance can be viewed remotely by customers and Bühler engineers. Faults can be diagnosed and performance optimised in any location using a laptop, tablet or smartphone.

Ultimate control.

\* All contracts are available for variable durations

## SORTEX upgrade kits.

Suitable for those who are seeking to upgrade sorters with an additional module, new features or software updates.

New technologies and innovations are continuously in development. Upgrade kits allow customers with existing machinery to enhance their production line with the very latest proprietary optical sorting technology.

## **Bühler AG**

Gupfenstrasse 5  
9240 Uzwil, Switzerland  
T +41 (0)71 955 11 11  
F +41 (0)71 955 33 79  
[www.buhlergroup.com](http://www.buhlergroup.com)

## **Business Unit SORTEX®**

20 Atlantis Avenue  
London E16 2BF  
United Kingdom  
T +44 (0)20 7055 7777  
F +44 (0)20 7055 7700  
[www.buhlergroup.com/sortex-a](http://www.buhlergroup.com/sortex-a)  
[sortexsales@buhlergroup.com](mailto:sortexsales@buhlergroup.com)